



Sequence Models

Machine Learning: Jordan Boyd-Graber
University of Maryland

LSTM VARIANTS

GRU simplifies slightly

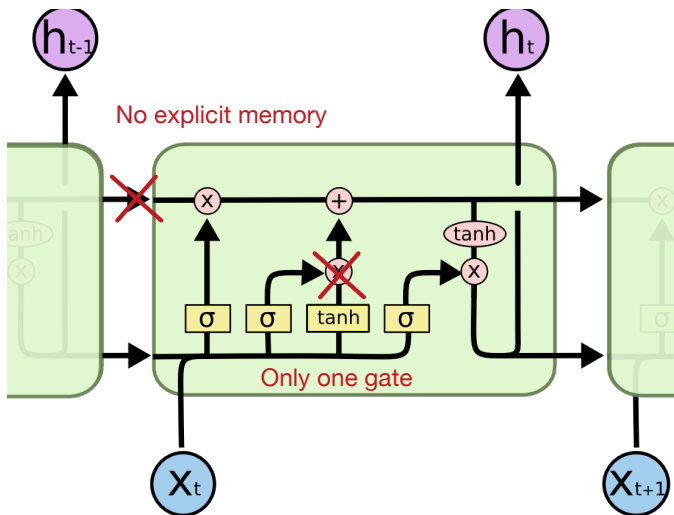

GRU simplifies slightly

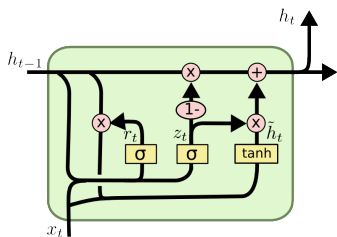

$$z_t = \sigma(W_z \cdot [h_{t-1}, x_t])$$

$$r_t = \sigma(W_r \cdot [h_{t-1}, x_t])$$

$$\tilde{h}_t = \tanh(W \cdot [r_t * h_{t-1}, x_t])$$

$$h_t = (1 - z_t) * h_{t-1} + z_t * \tilde{h}_t$$

Slightly fewer parameters

What's most important part of LSTM

Greff et al. explore

- No Input Gate (NIG)
- No Forget Gate (NFG)
- No Output Gate (NOG)
- No Input Activation Function (NIAF)
- No Output Activation Function (NOAF)
- No Peepholes (NP)
- Coupled Input and Forget Gate (CIFG) : GRU, $f_t = 1 - i_t$
- Full Gate Recurrence (FGR):
Original LSTM paper

What's most important part of LSTM

Greff et al. explore

- No Input Gate (NIG)
- No Forget Gate (NFG)
- No Output Gate (NOG)
- No Input Activation Function (NIAF)
- No Output Activation Function (NOAF)
- No Peepholes (NP)
- Coupled Input and Forget Gate (CIFG) : GRU, $f_t = 1 - i_t$
- Full Gate Recurrence (FGR):
Original LSTM paper

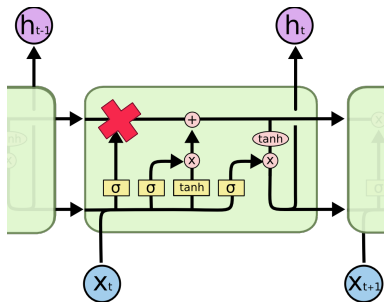

What's most important part of LSTM

Greff et al. explore

- No Input Gate (NIG)
- **No Forget Gate (NFG)**
- No Output Gate (NOG)
- No Input Activation Function (NIAF)
- No Output Activation Function (NOAF)
- No Peepholes (NP)
- Coupled Input and Forget Gate (CIFG) : GRU, $f_t = 1 - i_t$
- Full Gate Recurrence (FGR):
Original LSTM paper

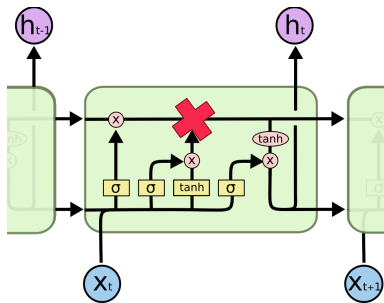

What's most important part of LSTM

Greff et al. explore

- No Input Gate (NIG)
- No Forget Gate (NFG)
- **No Output Gate (NOG)**
- No Input Activation Function (NIAF)
- No Output Activation Function (NOAF)
- No Peepholes (NP)
- Coupled Input and Forget Gate (CIFG) : GRU, $f_t = 1 - i_t$
- Full Gate Recurrence (FGR):
Original LSTM paper

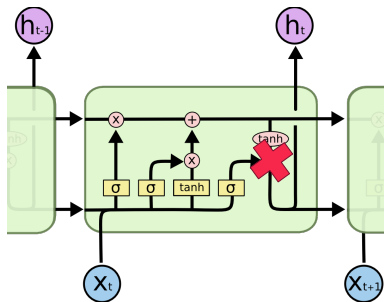

What's most important part of LSTM

Greff et al. explore

- No Input Gate (NIG)
- No Forget Gate (NFG)
- No Output Gate (NOG)
- **No Input Activation Function (NIAF)**
- No Output Activation Function (NOAF)
- No Peepholes (NP)
- Coupled Input and Forget Gate (CIFG) : GRU, $f_t = 1 - i_t$
- Full Gate Recurrence (FGR):
Original LSTM paper

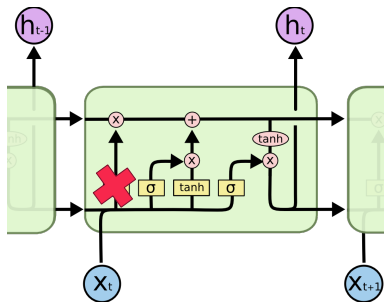

What's most important part of LSTM

Greff et al. explore

- No Input Gate (NIG)
- No Forget Gate (NFG)
- No Output Gate (NOG)
- No Input Activation Function (NIAF)
- **No Output Activation Function (NOAF)**
- No Peepholes (NP)
- Coupled Input and Forget Gate (CIFG) : GRU, $f_t = 1 - i_t$
- Full Gate Recurrence (FGR):
Original LSTM paper

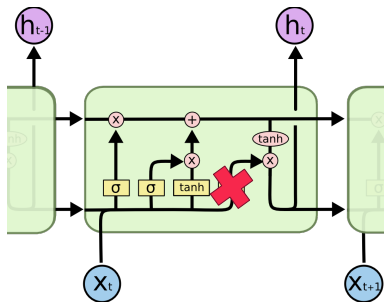

What's most important part of LSTM

Greff et al. explore

- No Input Gate (NIG)
- No Forget Gate (NFG)
- No Output Gate (NOG)
- No Input Activation Function (NIAF)
- No Output Activation Function (NOAF)
- **No Peepholes (NP)**
- Coupled Input and Forget Gate (CIFG) : GRU, $f_t = 1 - i_t$
- Full Gate Recurrence (FGR):
Original LSTM paper

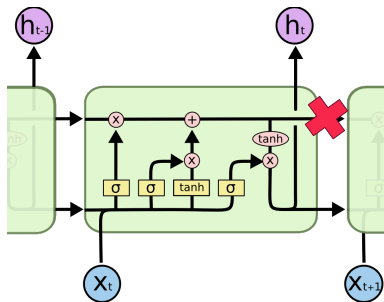

What's most important part of LSTM

Greff et al. explore

- No Input Gate (NIG)
- No Forget Gate (NFG)
- No Output Gate (NOG)
- No Input Activation Function (NIAF)
- No Output Activation Function (NOAF)
- No Peepholes (NP)
- **Coupled Input and Forget Gate (CIFG) : GRU, $f_t = 1 - i_t$**
- Full Gate Recurrence (FGR):
Original LSTM paper

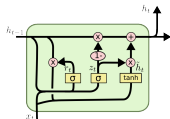

$$z_t = \sigma(W_z \cdot [h_{t-1}, x_t])$$

$$r_t = \sigma(W_r \cdot [h_{t-1}, x_t])$$

$$\tilde{h}_t = \tanh(W \cdot [r_t * h_{t-1}, x_t])$$

$$h_t = (1 - z_t) * h_{t-1} + z_t * \tilde{h}_t$$

What's most important part of LSTM

Greff et al. explore

- No Input Gate (NIG)
- No Forget Gate (NFG)
- No Output Gate (NOG)
- No Input Activation Function (NIAF)
- No Output Activation Function (NOAF)
- No Peepholes (NP)
- Coupled Input and Forget Gate (CIFG) : GRU, $f_t = 1 - i_t$
- Full Gate Recurrence (FGR):
Original LSTM paper

What's most important part of LSTM

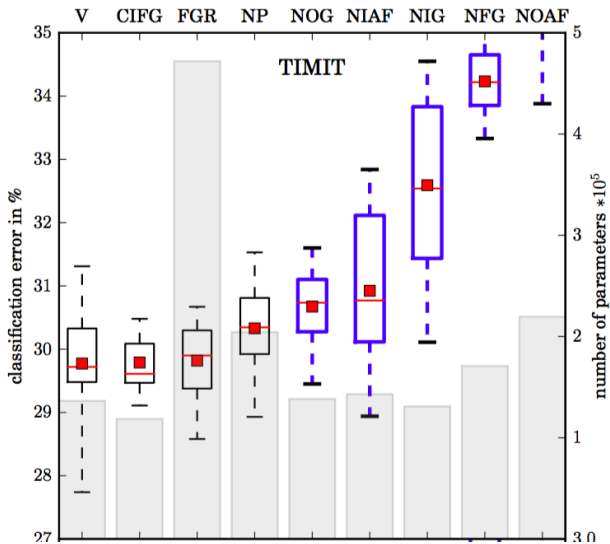

Bi-directional LSTMs

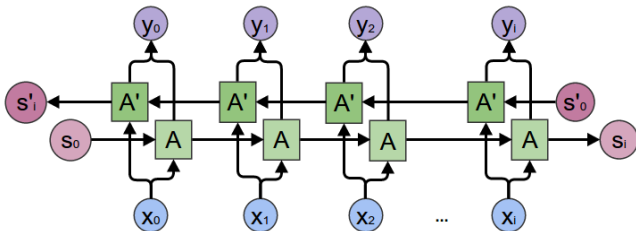

Simple extension, often slightly improve performance (but don't always make sense for task)

Comparing architectures

- GRUs seem competitive
- LSTM seems to be good tradeoff
- Bi-directional often offers slight improvement